

JIBBI

1670 EVO



PATENT PENDING



PRO ACTIVE LEVELLING

DYNAMIC LEVELLING

CRAWLER TELESCOPIC BOOM

ALMACRAWLER

JIBBI 1670 EVO

Piattaforma cingolata telescopica
da 16 metri di altezza.

16 mt crawler telescopic boom.

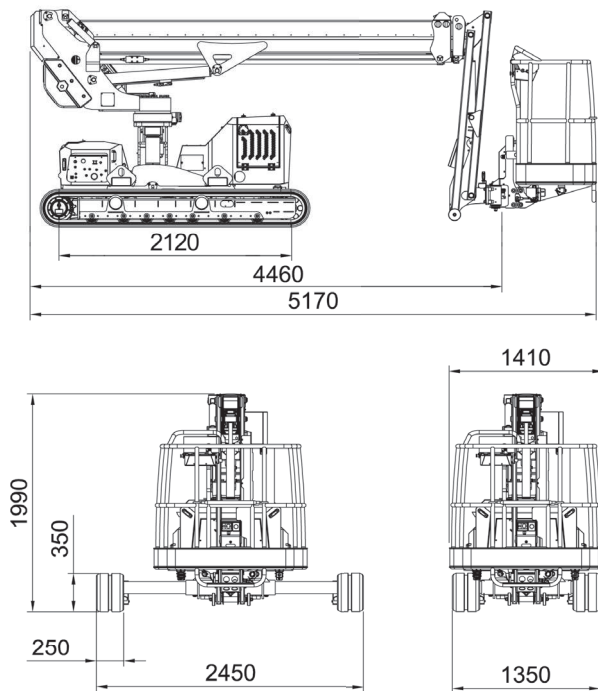

Integrated Drive System
Guida a singolo joystick
Using single joystick



Console via cavo by AUTECH
Cable remote console by AUTECH

MyAlmac
CONTROL PANEL



Pannello remoto impostazioni macchina
Machine settings remote control panel

Rotazione navicella
Basket rotation

+/- 70°



Rotazione ralla
Slewing ring rotation

+/- 110°



Sottocarro restringibile
Resizable undercarriage

1.35 / 1.90 / 2.45 mt



Dati tecnici**JIBBI 1670 EVO****Technical data**

Altezza massima di lavoro	16,00 m	Max working height
Altezza piano calpestio	14,00 m	Max height basket floor
Altezza di traslazione	9,00 m	Moving height
Sbraccio massimo (carico 80 Kg)	8,50 m	Max outreach (load 80 kg)
Sbraccio massimo (carico 140 Kg)	7,70 m	Max outreach (load 140 kg)
Sbraccio massimo (carico 230 Kg)	6,70 m	Max outreach (load 230 kg)
Angolo di rotazione torretta	+/-110°	Rotation angle
Dimensioni navicella	1,40 x 0,70 m	Basket size
Angolo di rotazione navicella	+/- 70°	Basket rotation angle
Portata massima in navicella	230 kg	Max basket capacity
Lunghezza richiusa (navicella smontata)	5,10 (4,40) m	Length in stowed position (with detached basket)
Larghezza minima richiusa	1,35 m	Min width in stowed position
Larghezza media di lavoro	1,90 m	Medium working width
Larghezza massima di lavoro	2,45 m	Max working width
Altezza minima richiusa	1,99 m	Min height in stowed position
Livellamento longitudinale	+/- 15°	Longitudinal leveling
Livellamento laterale	+/- 15°	Lateral leveling
Pendenza massima superabile	25°	Max gradeability
Pendenza laterale massima	25°	Max side gradeability
Velocità traslazione (veloce)	2,50 km/h	Drive speed (fast)
Velocità di traslazione in condizione di trasporto	0,40 km/h	Speed over transport condition

Pesi**Weights**

Carico al suolo	3,1 kN/m ²	Traffic load (max working width)
Peso totale	3850 kg	Total weight

Potenza**Power**

Motore Yanmar 3TNM68-AS diesel	14 kW - 19,2 Hp @3600rpm	3TNM68 -AS Yanmar engine (diesel)
--------------------------------	--------------------------	-----------------------------------

Allestimenti a richiesta**Extras - On Demand**

Navicella grande	1,80 x 0,70 m	Wide Basket
Cingoli antitraccia	-	Non-marking tracks
Elettropompa 220V-2,2Kw / 50Hz (Peso +30 Kg)	-	Electric pump 220V-2,2KW / 50Hz (Weight +30 Kg)
Kit radiocomando con batteria ricaricabile	-	Radio remote control with rechargeable battery
Kit lubrificante per clima artico	-	Arctic lubricant for cold climate
Kit verricello 200 kg	-	Winch kit 200 kg
Sistema Anti-collisione ad ultrasuoni	-	Ultrasonic Anti-collision System

Dimensione navicella

Basket size

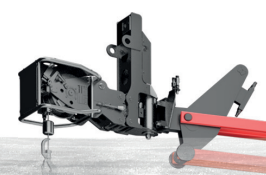
Standard
1.4 mtOptional
1.8 mt**Verricello**
Winch

Optional

ALMACRAWLER

JIBBI 1670 EVO

- 80 kg
- 140 kg
- 230 kg

16.0m	230kg	19.2Hp	+/-15°	2.5 km/h	+/-15°
MAX W.H.	CAPACITY	POWER	LONG. LEVEL.	SPEED	LATER. LEVEL.

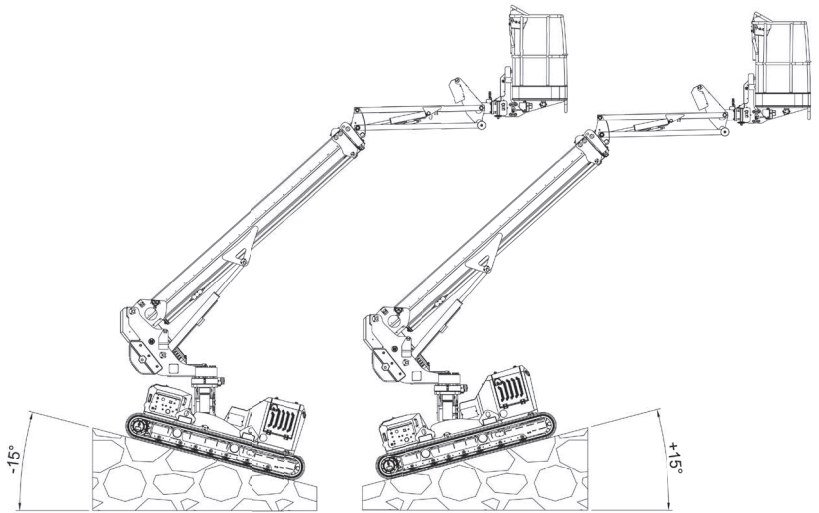
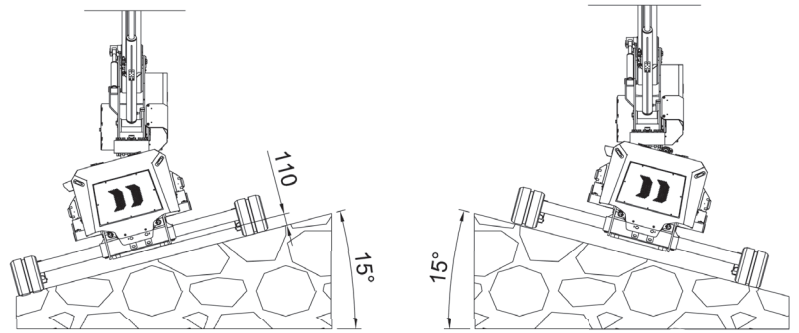
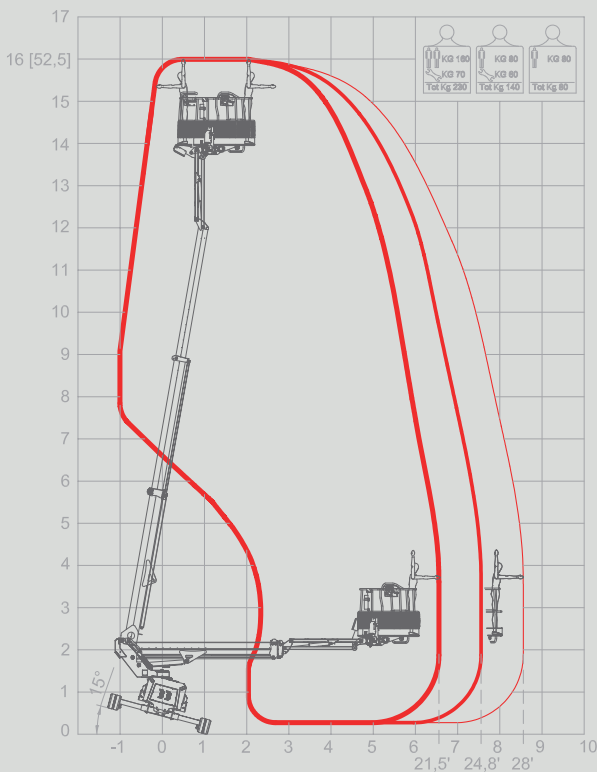
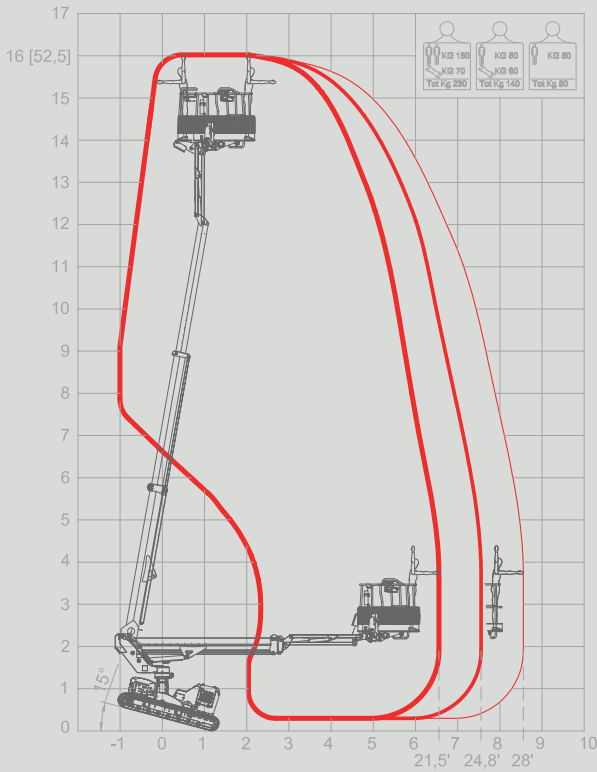

UNDERCARRIAGE CONFIGURATIONS & WORKING AREAS

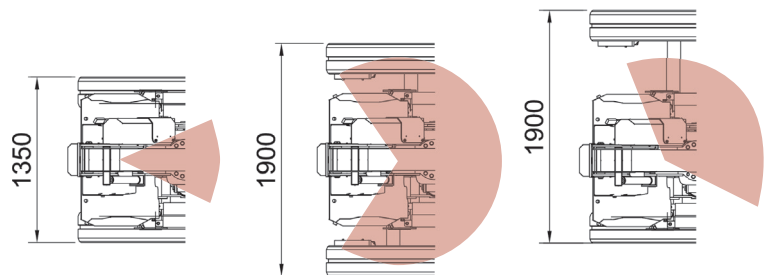
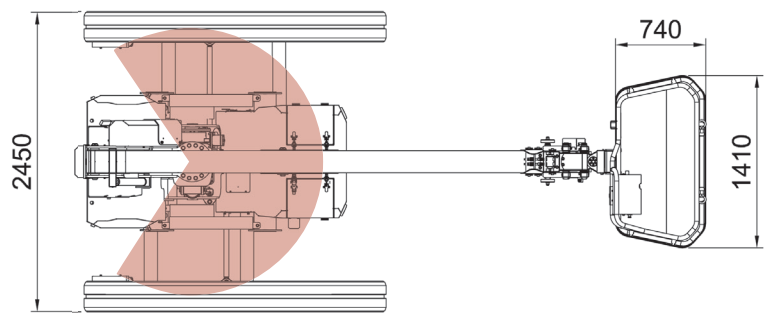

Via Caduti sul Lavoro 1
46019 Viadana (MN) - ITALY
+39 0375 83 35 27
info@almac-italia.com

ALMACRAWLER

ALL DATA REPORTED IN THIS CATALOGUE ARE NOT BINDING. ALMAC SRL RESERVES THE RIGHT TO CHANGE SPECIFICATIONS WITHOUT PRIOR NOTICE.